

FIAT COUPÉ



FIAT

FIAT



COUPÉ



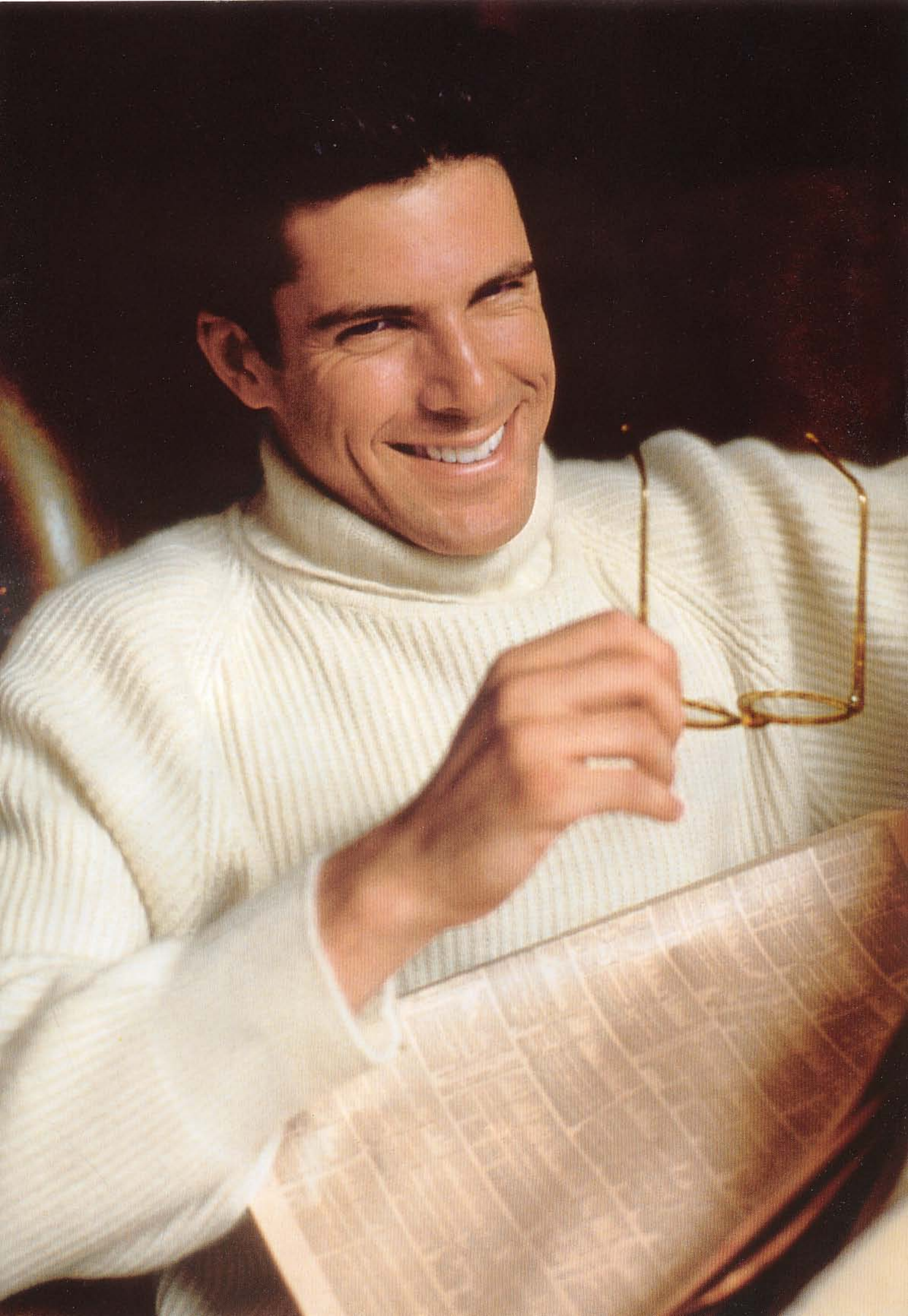

DRIVEN BY PASSION.

Cars are a passion for us. But before we think of the car itself, we always think of the person who drives one. And those who don't, of course. This is why new Fiats are the fruit of a design culture that focuses first of all on the quality of life. So before we talk about our cars, we are going to talk about the values of life.

SAFETY

It is the design credo of every Fiat. Reinforced crumple-zone body. Non-deforming cabin structure. Protection against side-on impact. EAS Energy absorbing steering wheel with collapsible column. Fire prevention system (FPS) with inertia switch and twin fuel flow-stop valves. Airbag. ABS. Electronic security key with Fiat CODE engine immobiliser.

TRUST

We look after you before you even get into your new Fiat. "Patto Chiaro" is the contract that makes the purchasing conditions of your new car absolutely transparent, guaranteeing a range of services free of charge, in addition to those in the warranty. And that is not all. Because we also propose a number of other services. All you have to do is choose the ones that meet your needs.

THE ENVIRONMENT

We respect nature. Our cars respect all the latest EC exhaust emissions standards. We have eliminated all harmful substances from manufacturing processes. All Fiats can be recycled at the end of their life cycle, by the advanced Fiat Auto REcycling system (F.A.RE.).

FREEDOM

Individual mobility is the most important civil right.

And the car is the best way of achieving it. But today there are about 500 million men and women in the world with disabilities who are unable to use one. Fiat designs its cars right from the start so that they can be used by people with these problems.

If you have chosen a Fiat, it means that we see eye to eye on the value of life, and the car. So we already have something in common.

We are driven by passion.

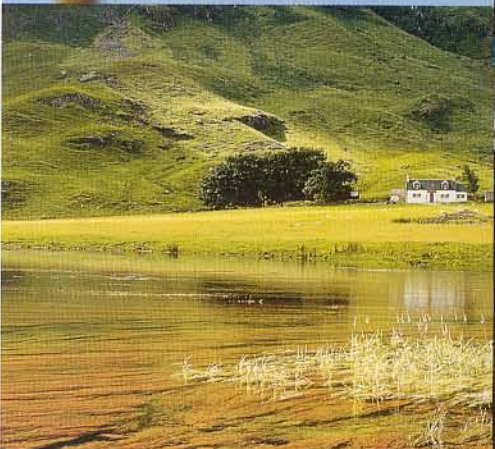

ON THE WINGS OF THE WIND.

Assertive style. A flowing, sleek line created by the Fiat Style Centre and Pininfarina. The perfect expression of styling research that achieves a perfect balance between original design trends and the classical refinement that has always set Italian sports cars apart the moment you set eyes on them.

A sporty temperament. Three engines, an aspirated 1.8 with 16 valves, and a 2.0 with 5 cylinders and 20 valves in aspirated and turbocharged versions, provide exciting performance with full respect for the environment. Its outstanding engineering is a guarantee of the highest levels of dynamic safety, and the emotion of driving a sports car, the result of direct dialogue between driver and road.

A reliable personality. The most advanced passive safety features are standard equipment: reinforced crumple-zone body, non-deforming cabin structure, impact beams in the doors, pretensioned seat-belts. EAS energy absorbing steering wheel with collapsible column, airbags for driver and passenger, FPS fire prevention system.

Who would have thought it. There are times when technology surpasses our imagination.

Fiat Coupé. On the wings of the wind.







ASSERTIVE STYLE.

Speed is not merely a physical condition linked to movement. For us it is first and foremost a mental state. An element introduced at the moment of creation that will rapidly transform intuition into reality. This is why we ask you to stop a moment while we talk of speed.



Let us show you the Fiat Coupé, the outcome of collaboration between the Fiat Style Centre and Pininfarina; a stylish, assertive sports car, ultimate expression of extremely sophisticated research into form, conducted to achieve a perfect blend of innovation and respect for the sophis-

ticated, distinctive lines of Italian design.

The outline of the Fiat Coupé is strongly characterised by two raked grooves at the height of the front and rear wheel arches. These visibly propel the car forward as if about to pounce on the road, conjuring up the idea of

physical power under perfect control.

The front end reiterates all the outward signs of a strong, assertive personality: horizontal grille, bonnet with no visible joins, large air intakes in the bumpers. The plunging wrap-around bonnet includes aerodynamically faired



headlamps, just one example of a universe of unmistakable details; like the quick-release fuel cap and the circular rear light clusters positioned in the cut-off, slightly raised rear end copied from great Italian sports cars of the past that have provided the inspiration for the Fiat Coupé.

The car's elegant styling is enhanced by a range of eight colours, pastel and metallic, designed to set off the car's muscular line.

- Design by Pininfarina-Fiat Style Centre
- Faired polyelliptical front light clusters
- Cut-off raised rear end
- Third brake light
- Quick release fuel cap

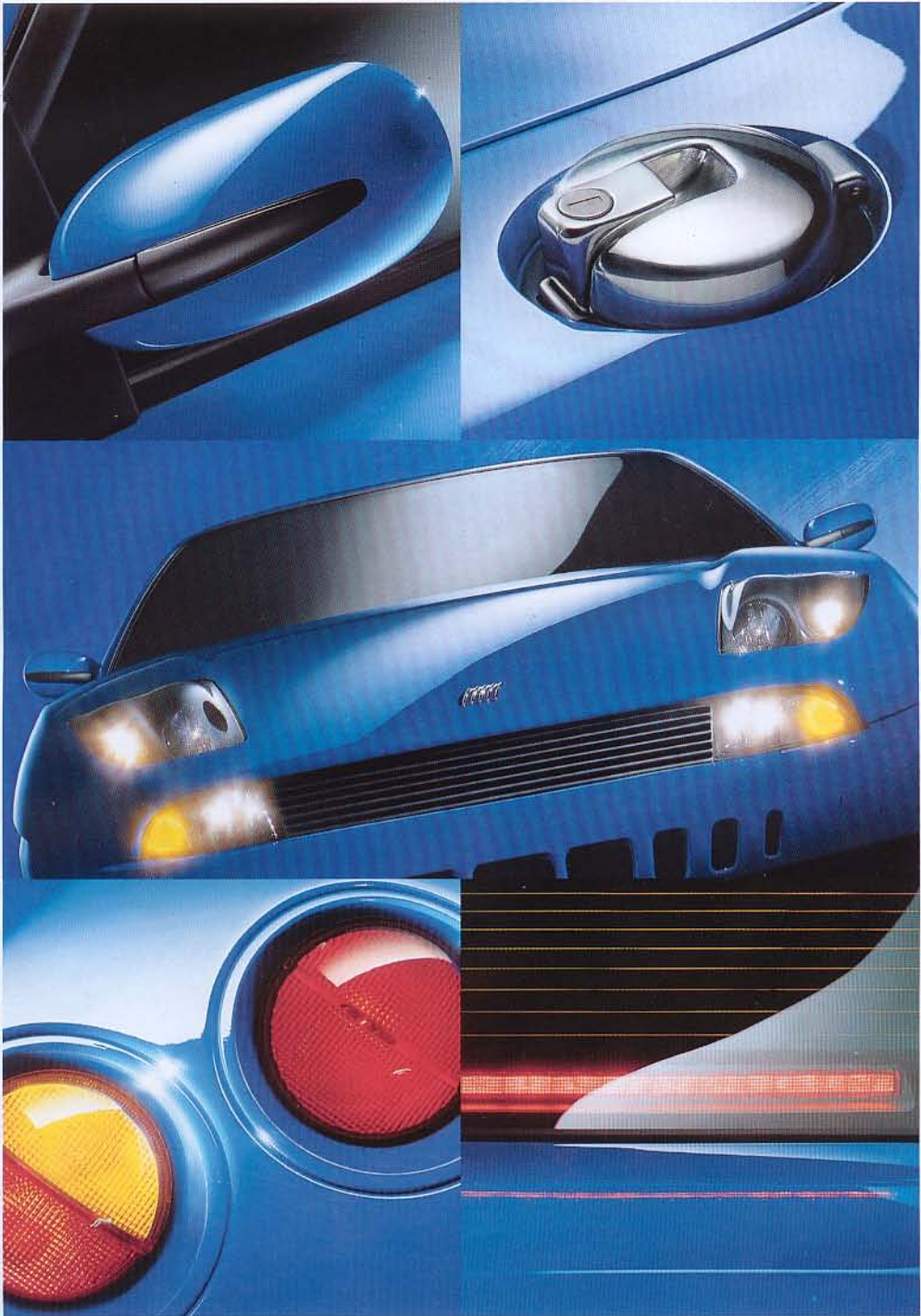



This is our idea of what the cockpit of a thoroughbred sports car should be. Make yourselves at home. A horizontal car-coloured band traverses the fascia and door panels, underlining the fluid, protective, enveloping volumes.

The three-spoke steering wheel, complete with airbag, and

the gear lever knob are shaped anatomically. The analogue instruments are protected by an anti-glare lip and clustered in circular gauges with sporty, easily-read graphics with light figures on a black background: speedometer, rev counter, engine coolant temperature, fuel level, oil pressure



and engine oil temperature indicators. The central console houses the heating and ventilation controls, the analogue clock and the secondary service switches.

- Body-coloured insert on the fascia and door panels
- Ergonomic steering wheel and gear lever grip
- Driver's airbag standard, passenger airbag on request
- Sporty analogue instrumentation
- Analogue clock on central console



1.8 16v
2.0 20v
2.0 20v TURBO:
A COMPREHENSIVE
RANGE.

The Fiat Coupé is available with three engines and a single trim level.

If you wish to combine a sparkling driving style with fuel consumption that is low for a car offering this level of performance, the Fiat Coupé 1.8 16v is the car



for you. If you are looking for an elegant sports car at the peak of the 2.0 litre class, then you have found it: the Fiat Coupé 2.0 20v. If on the other hand you want to enjoy an uncompromising sporty driving style, then you will love the Fiat Coupé 2.0 20v Turbo.

FIAT COUPÉ • ENGINES

1.8 16v	130 bhp - 205 km/h
2.0 20v	147 bhp - 212 km/h
2.0 20v Turbo	220 bhp - 250 km/h

Three different ways of enjoying the Fiat Coupé, a modern,

rational sports car that is agile and sparkling in town traffic, fast and aggressive on the open road.

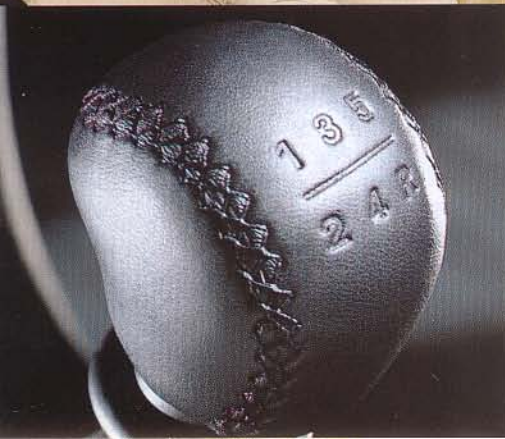

A COMFORTABLE, RATIONAL SPORTS CAR

The Fiat Coupé has a well-lit passenger compartment, outfitted with the same elegant furnishings on all versions, that offers four "real" seats and a quality of life on board that is comparable with that of a saloon.

The sporty front seats offer good lateral hold on corners. The passenger seat is fitted with a tilt and slide device, for better access to the back seat. The search for maximum comfort is evident in details such as the front and rear side arm rests, the capacious pockets in the door panels and on the rear of the front passenger seat squab, and the oddments container on the central console, which also houses the electric window and door mirror controls.

Upholstery is in grey-black woven cloth but there is also the option of leather in four colours to match those of the body.

The automatic climate control system with pollen filter, which is standard with the 2 litre engines, includes a "max def"

function for rapid windscreen demisting. The Fiat Coupé 1.8 16v has a heating and ventilation system with air recirculation and a split-level function that delivers cooler air to face-level outlets and warmer air to footwell outlets.

And there is more. The Fiat Coupé also has a real luggage compartment, measuring 295 dm³, and the rear seat squab folds down to provide even more loading space.



FIAT COUPÉ • EQUIPMENT

	1.8 16v	2.0 20v	2.0 20v Turbo
Driver's airbag	•	•	•
Leather steering wheel and gear lever knob	◦	•	•
Climate control	◦	•	•
Rear wash/wipe	◦	•	•
ABS	◦	•	•
15" alloy wheels	◦	•	—
16" alloy wheels	—	—	•
Viscodrive	—	—	•

• = standard ◦ = optional — = not available









**A SAFE
PERSONALITY.**

At the wheel of the Fiat Coupé you will feel one with the car and the road, and it won't be just an impression.

It is the concrete result of a state-of-the-art project, the guarantee of unequalled driving enjoyment and the highest possible level of dynamic safety: front



wheel drive, independent suspension with segmented dampers, Viscodrive on the Fiat Coupé 2.0 20v Turbo, split crossover braking circuits and ABS on the Fiat Coupé 2.0 20v and 2.0 20v Turbo, which also fits special 16" alloy wheels.

The three engines in the

range, with 4 and 5 cylinders, naturally aspirated and turbocharged, all multivalve units, belong to the latest generation of Fiat engines, the product of extremely sophisticated computer science extended from the first stages of design with CAE (Computer Aided Engineering) tech-

nologies, to quality controls at the end of the manufacturing process.

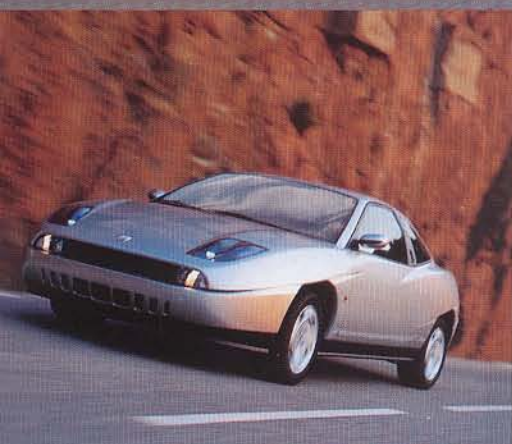
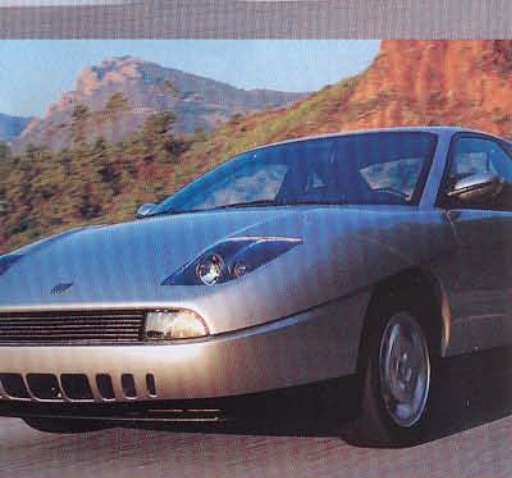

**DRIVING ENJOYMENT
AND DYNAMIC
SAFETY**

The Fiat Coupé is fitted with an independent, all-round suspension system. A MacPherson layout at the front comprises transverse wishbones and negative kingpin offset with an anti-roll bar fastened to a rigid frame. The independent rear suspension system includes an anti-roll bar fastened to longitudinal wishbones. Segmented dampers ensure maximum damping efficiency, low noise levels and smooth reactions, combined with better roadholding and grip under all conditions. In order to exploit its higher torque and maximum power output, the Fiat Coupé 2.0 20v Turbo is equipped with a Viscodrive viscous coupling applied to the differential unit. The Viscodrive really comes into its own on corners and over slippery surfaces. It lessens the chances of the front wheel with least grip skidding and allows drive torque to be transferred to the wheel with better grip. During fast driving, the Viscodrive improves han-

- **Front-wheel drive**
- **Independent suspension**
- **Segmented dampers**
- **Twin circuit crossover braking system**
- **Four disc brakes**
- **ABS standard on 5-cylinder engines**
- **Up-rated braking system on 2.0 20v Turbo**
- **Viscodrive on 2.0 20v Turbo**

dling on corners and stabilises trajectories to make a significant contribution to active safety. The braking system comprises four generously sized discs, ventilated at the front, and is powerful and effective under all conditions. When combined with the negative kingpin offset of the front suspension system, the cross-over circuit renders the car controllable even if one of the two circuits should accidentally fail, allowing the car to be braked on both sides. Versions powered by the 2.0 20 valve en-



gine are fitted with a tandem brake servo as standard, which ensures prompt, more effective braking, even after prolonged use, combined with a 4-channel, 4-sensor Bosch ABS system.

Because of its outstanding performance, the braking system on the Fiat Coupé 2.0 20v Turbo includes a number of specific features developed with Brembo: aluminium brake calipers, fixed 4-piston front calipers with larger ventilated discs and pads optimised by better distribution of the pressure on the disc and a larger friction surface.

PASSIVE SAFETY

The Fiat Coupé looks after you, with the most advanced passive safety features.

The reinforced body shell with side impact beams in the doors has passed the most stringent impact tests with flying colours. The rigid passenger compartment structure was conceived as a non-deformable "survival cell". All versions are fitted as standard with anatomical front head-restraints, pre-tensioned front seat-belts, seats with a ridge inside the cushion to prevent the body from slipping out in the case of impact (submarining effect), energy absorbing steering wheels (EAS) with an airbag and

collapsible steering column, FPS fire prevention system with inertia switch and double anti-reflux valve fitted to the tank to prevent fuel from leaking. A passenger airbag is an option on all versions.

- Reinforced bodyshell
- Side impact beams
- Non-deformable passenger compartment
- Pre-tensioned seat-belts
- EAS steering wheel complete with airbag
- FPS fire prevention system
- Fiat CODE electronic security key and immobiliser

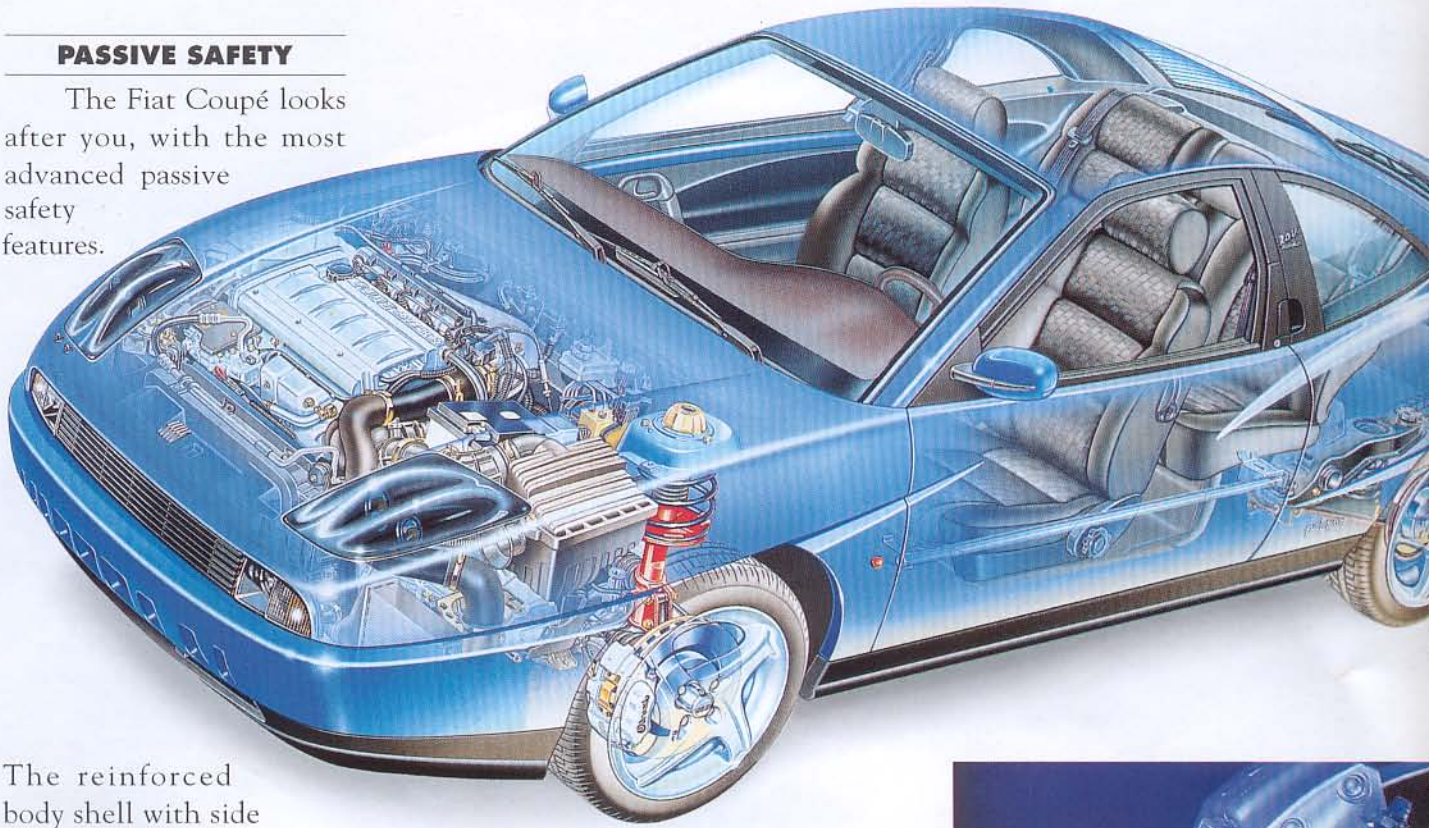

Front wheel drive, independent suspension, segmented dampers, four disc brakes.

Disc brakes.

The Viscodrive coupling.

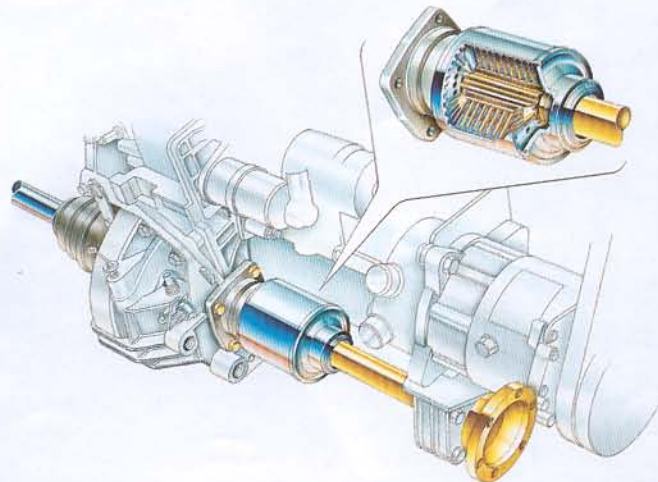



FIAT

AIRbag

1.8

16v

Capacity 1747 cc
130 bhp-EC at 6300 rpm
16.7 kgm-EC at 4300 rpm
Top speed of 205 km/h
0-100 km/h acceleration
in 9.2 secs.

4 cylinders in line with 8 counterweights on the crankshaft and torsional damping. Twin overhead cam timing with electrohydraulic variable valve timing and 4 valves per cylinder with hydraulic tappets. MPI phased sequential electronic injection with hot film controlled air flow and electronic ignition with static advance combined with the injection.

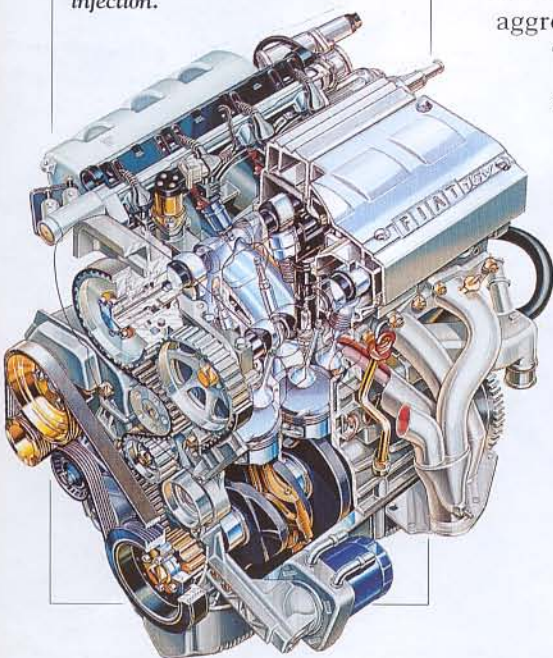

The comprehensive standard equipment on the Fiat Coupé 1.8 16v includes a driver's airbag.

A number of constructional features put the 1.8 16v engine at the peak of its category in terms of performance, reliability and low running costs. The aluminium alloy cylinder head. The nodular cast iron crankshaft with eight counterweights and torsional damping. The hydraulic tappets. The combined electronic management of ignition and injection.

The variable valve timing on the camshaft axis which intervenes in advance of intake valve opening to achieve the best balance between power, torque and emissions: at low revs the intake phasing is advanced to improve torque, while it is delayed at high revs to boost performance.

The result is an extremely flexible engine, which delivers 90% of peak torque between 2000 and 6000 rpm, fluid in traffic and aggressive on the open road.

This engine is extremely satisfying to drive, with its excellent flexibility and performance, accelerating from 0 to 100 km/h in 9.2 seconds, and achieving a top speed of 205 km/h.



Optional leather upholstery.

The passenger seat with tilt and slide mechanism.

The special wheel trims of the Fiat Coupé 1.8 16v.





2.0

20v

Capacity 1998 cc
147 bhp-EC at 6100 rpm
19 kgm-EC at 4500 rpm
Top speed of 212 km/h
0-100 km/h acceleration
in 8.9 secs.

5 cylinders in line with a counter-rotating balancer shaft, 4 valves per cylinder with hydraulic tappets. Twin overhead cam timing with electrohydraulic variable valve timing. MPI phased sequential electronic injection with hot film controlled air flow and electronic ignition with static advance combined with the injection, single coils on each spark plug and selective knock control.

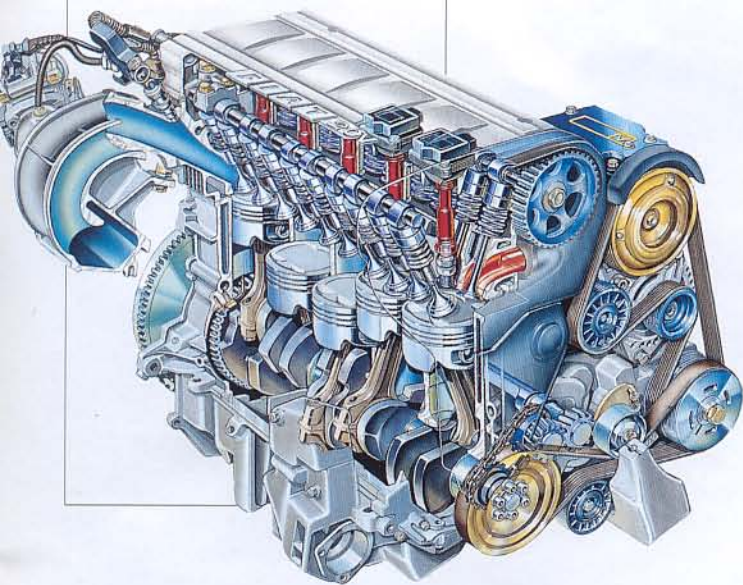

category include a counter-rotating balancer shaft which ensures extremely smooth, quiet operation. The aluminium alloy pistons have press-fitted graphite inserts to limit friction and enhance reliability. For the same reasons, the lubrication system includes a water-oil heat exchanger mounted directly on the oil pump, with no external pipes.

This engine guarantees performance at the top of the 2.0 litre class: 8.9 seconds to accelerate from 0 to 100 km/h and a top speed of 212 km/h.

Standard equipment on the Fiat Coupé 2.0 20v is particularly lavish, and includes a driver's airbag, sewn leather covered steering wheel and gear lever knob, automatic climate control, ABS and special 15" alloy wheels.

The 2.0 20 valve 5-cylinder engine runs smoothly and fluidly at all speeds, comparable to an engine with 6 cylinders in line, but more compact and lighter, with obvious advantages in terms of handling. The many features that put this engine at the top of its

Analogue clock.

Rational, fully exploitable luggage compartment.

Automatic climate control dials.

15" alloy wheels.



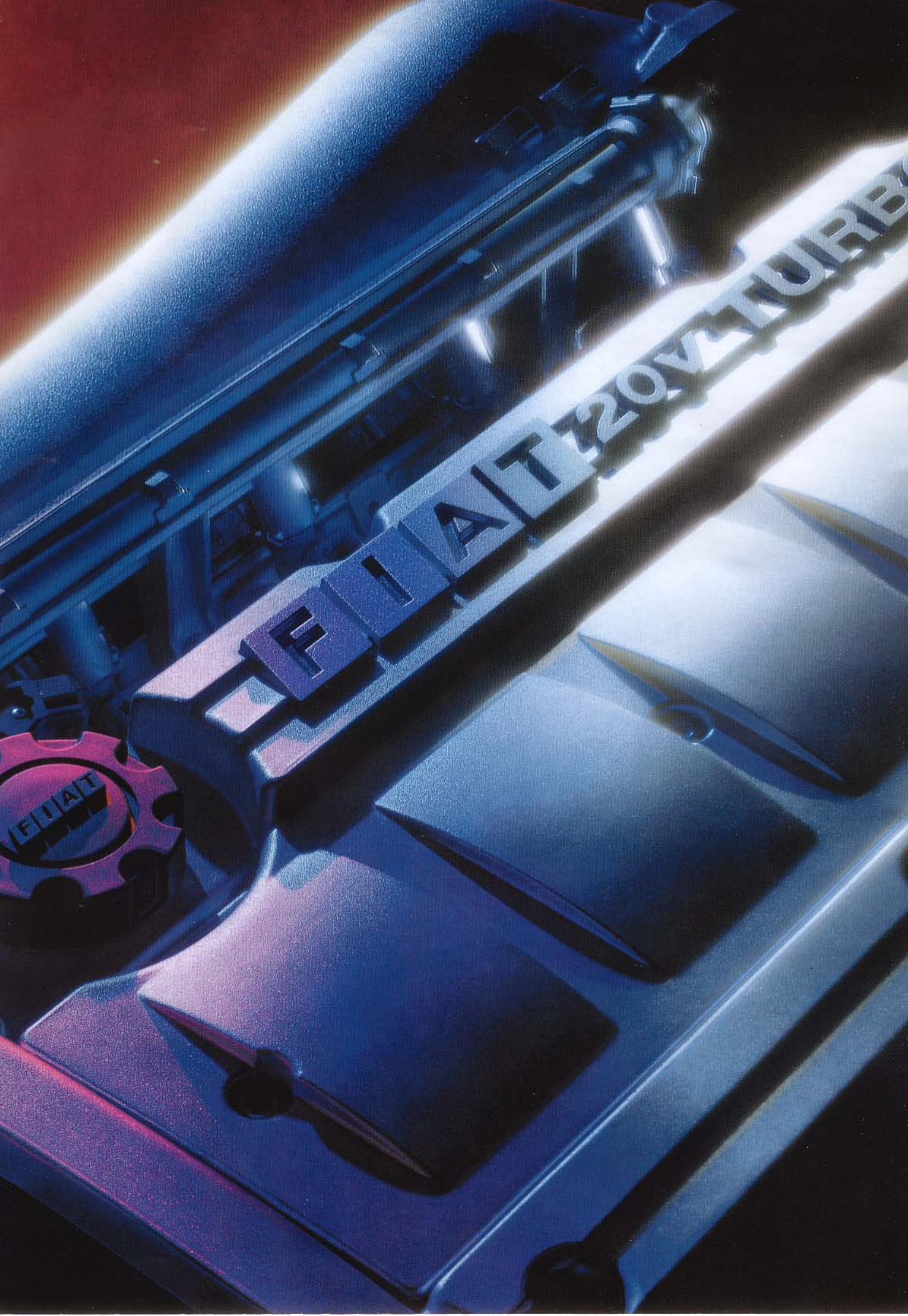

FIAT 20V TURBO



2.0

20v Turbo

Capacity 1998 cc
220 bhp-EC at 5750 rpm
31.6 kgm-EC at 2500 rpm
Top speed of 250 km/h
0-100 km/h acceleration
in 6.5 secs.

5 cylinders in line with a counter-rotating balancer shaft, 4 valves per cylinder with hydraulic tappets. Twin overhead cam timing with electrohydraulic variable valve timing. MPI phased sequential electronic injection with hot film controlled air flow and electronic ignition with static advance combined with the injection, single coils on each spark plug and selective knock control. Garrett turbo compressor with incorporated wastegate valve and intercooler.

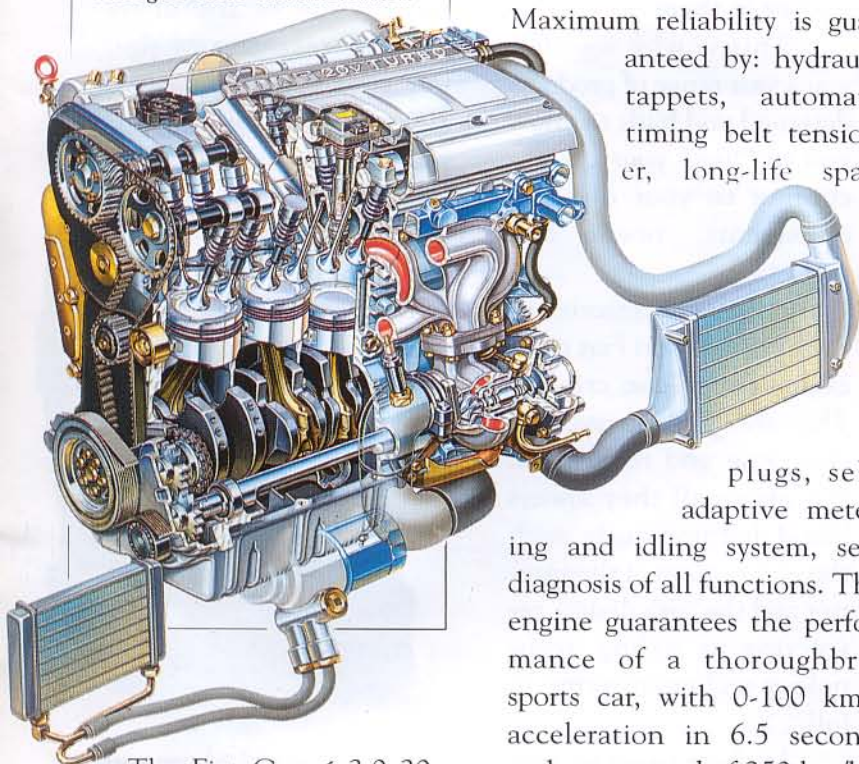

The Fiat Coupé 2.0 20v Turbo features all the standard equipment of the aspirated 2.0 20v, plus Viscodrive and special 16" alloy wheels.

The engine has the same cylinder block, crankshaft and cylinder head as the naturally aspirated version: all the rest was redesigned.

The electronic management system that combines single coil ignition and phased

sequential Multipoint injection is a Bosch Motronic M 2.10.4 unit with hot film flow control, active knock control on each cylinder, and control of the variable valve timing, the electric cooling fans and the turboboost level.

The turbo-compressor guarantees an excellent air flow (over 700 kg/h) and low inertia. All the internal and external fluodynamics of the engine was refined to this end: intake manifold, exhaust manifold, stainless steel intake valves, sodium-cooled exhaust valve, new pistons, steel conrods, air-oil intercooler. Maximum reliability is guaranteed by: hydraulic tappets, automatic timing belt tensioner, long-life spark

plugs, self-adaptive metering and idling system, self-diagnosis of all functions. This engine guarantees the performance of a thoroughbred sports car, with 0-100 km/h acceleration in 6.5 seconds and a top speed of 250 km/h.

Optional sunroof.

ABS is standard.

Document pocket on the rear of the passenger seat.

Special 16" alloy wheels.

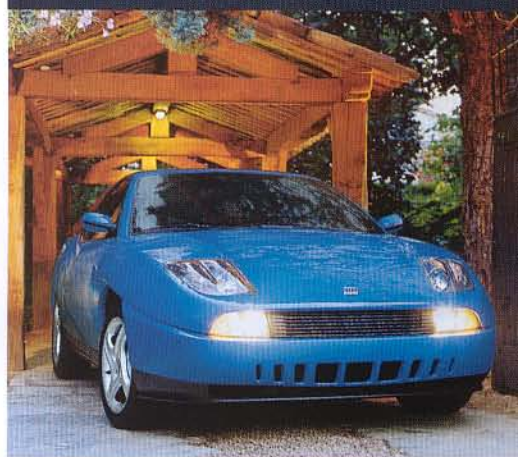



LINEACCESSORI FIAT: TO ENJOY YOUR CAR MORE.

Cars are not just for travelling. We use them to listen to music, to telephone, to go out with friends, to go to work, to go on holiday. In other words, we live in them.

This is why we offer you a vast range of products designed and built to allow you to "live" your car according to your own requirements, needs and wishes.

All the accessories in the Lineaccessori Fiat meet extremely precise criteria. They are simple to use, reliable, safe and functional. But above all they always blend harmoniously with the ergonomics of the interior and the car's design, respecting its styling, technology and engineering in full.

In these pages we present a few products from the Fiat accessory line which complement and complete the list of factory-mounted options that can be ordered with the car.

As you will see, we have thought of practically everything. Yet again you are at the centre of our attention. But don't let that embarrass you. For us it is merely one of the many ways we take care of you, day after day. In your free time and at work. In town and in the open air.

Of course, our dealers will be pleased to illustrate the entire



range to you and advise you in your choice.

Lineaccessori Fiat. To enjoy your car more.

- Spoiler
- Sideskirts
- Aerodynamic front bumpers
- Aerodynamic strip on the rear bumper
- Recaro sports seats
- Sports pedals
- Low spring kit
- Radio and hi-fi accessories
- Sunshades
- Electronic antitheft systems
- Reverse sensor
- Magnetic ski holder
- All-purpose bars
- Mats
- Seat covers
- Cellular telephone
- Indoor and outdoor car covers

FIAT
Lineaccessori



TECHNICAL SPECIFICATIONS

	1.8 16v	2.0 20v	2.0 20v Turbo
ENGINE			
No of cylinders, arrangement	4, in line, front transverse	5, in line, front transverse with counter-rotating shaft	5, in line, front transverse with counter-rotating shaft
Bore x Stroke (mm)	82 x 82.7	82 x 75.65	82 x 75.65
Capacity (cc)	1747	1998	1998
Compression ratio	10.3 : 1	10.0 : 1	8.5 : 1
Max. power: bhp-EC (kW-EC) at rpm	130 (96) 6300	147 (108) 6100	220 (162) 5750
Max. torque: kgm-EC (Nm-EC) at rpm	16.7 (164) 4300	19 (186) 4500	31.6 (310) 2500
Timing gear (drive)	2 OHC (toothed belt) with variable valve timing and hydraulic tappets		
Fuel System	phased sequential electronic MPI	phased sequential electronic MPI	phased sequential electronic MPI with turbo and intercooler
Ignition	electronic, static advance integrated with injection		
TRANSMISSION			
Drive	front	front	front
Gears: 1st	3.909 : 1	3.545 : 1	3.800 : 1
2nd	2.238 : 1	2.238 : 1	2.235 : 1
3rd	1.520 : 1	1.520 : 1	1.520 : 1
4th	1.156 : 1	1.156 : 1	1.156 : 1
5th	0.946 : 1	0.919 : 1	0.914 : 1
Reverse	3.909 : 1	3.909 : 1	3.545 : 1
Final drive ratio	3.562 : 1 (16/57)	3.562 : 1 (16/57)	3.111 : 1 (18/56)
STEERING			
Steering box	rack and pinion with power steering	rack and pinion with power steering	rack and pinion with power steering
Turning circle between kerbs (m)	10.3	10.3	10.4
BRAKES - D (disc) - T (drum)			
Front: dia. mm	D 284 (ventilated)	D 284 (ventilated)	D 305 (ventilated)
Rear: dia. mm	D 251	D 251	D 251
SOSPENSIONI			
Front	independent MacPherson type with transverse lower wishbones anchored to an auxiliary cross-beam, offset coil springs and anti-roll bar		
Rear:	independent, with trailing arms anchored to an auxiliary sub-frame, coil springs, and anti-roll bar		
DIMENSIONS			
Wheelbase (mm)	2540	2540	2540
Front/rear track▲ (mm)	1483/1468	1483/1468	1491/1468
Length/width/height▲ (m)	4.25/1.76/1.35	4.25/1.76/1.34	4.25/1.76/1.34
Luggage capacity VDA (dm ³)	295	295	295
WHEELS			
Tyres	195/55 R 15 V	205/50 R 15 W with alloy wheels	205/50 R 16 Y with alloy wheels
ELECTRICAL EQUIPMENT (12V)			
Battery capacity (Ah)	50	50	50
Generator (A)	75 (85 with climate control)	85	100
CAPACITIES-WEIGHTS			
Fuel tank capacity (litres)	63	63	63
DIN kerb weight (kg)	1180	1270	1310
PERFORMANCE			
Top speed (km/h)	205	212	250
Acceleration (secs): 0-100 km/h	9.2	8.9	6.5
(2 adults + 20 kg) 0-1000 m	30.4	29.9	26.3
Pick-up from 60 km/h in 5th over 1000 m (s.)	33.0	32.5	29.3
FUEL CONSUMPTION (l/100 km)			
EC Directive 93/116			
urban / out-of-town / combined cycles	11.9 / 6.8 / 8.6	14.0 / 7.3 / 9.8	14.4 / 7.6 / 10.1

▲ Unladen

STANDARD AND OPTIONAL EQUIPMENT

	1.8 16v	2.0 20v	2.0 20v Turbo
OUTSIDE			
Body-coloured bumpers			
Athermic windows			
Black side window frames and central pillar			
Black door handles recessed in door pillars			
Aluminium rapid release fuel filler cap			
Electrically operated, heated body-coloured door mirrors			
Heated rear window			
Foglights			
Polyelliptical halogen headlights			
Two incorporated reversing/rear foglights			
Rear wash/wipe with intermittency control	•		
15" alloy wheels with larger tyres	•		-
16" special alloy wheels with larger tyres	-	-	
Headlamp washers	•	•	•
Metallic paint	•	•	•
Electric sunroof	•	•	•

INSIDE			
Driver's seat with lumbar adjustment			
Tilt-slide front passenger seat with memorised position			
Height-adjustable head-restraints			
Fold-down rear seat squab			
Cloth upholstery			
Velour floor covering with shield on driver's side			
Steering wheel with axial and height adjustment			
Passenger seat squab pocket			
Illuminated lighter			
Oddments pocket on both front doors			
Locking illuminated fascia glove compartment			
Front/rear ashtray			
Equipped central console			
Loudspeaker housings in fascia, doors and rear sides			
Fully carpeted luggage compartment with luggage restraints and lighting			
Leather steering wheel and gear lever knob	•		
Leather upholstery (4 colours, including velour carpet)	•	•	•
Heated front seats	•	•	•

SAFETY			
Driver's airbag			
FPS fire prevention system with inertia switch on fuel pump and anti-reflux valve on fuel return lines			
Height-adjustable pre-tensioned front seat-belts			
EAS energy absorbing steering wheel			
Safety steering system with telescopic column			
Crumple-zone body shell			
Front and rear seats with anti-submerging beam			
Impact beams in doors			
4-channel, 4-sensor Bosch ABS	•		
Passenger's airbag	•	•	•

	1.8 16v	2.0 20v	2.0 20v Turbo
FUNCTIONAL / ELECTRIC			
Power steering			
Electric front windows with one touch control on driver's side			
Central locking			
3rd brake light			
Fiat CODE			
Twin tone horn			
Analogue clock			
Rev counter			
Oil pressure gauge			
Water and oil temperature gauge			
Trip counter			
4-speed ventilation system with bi-level function and "max defrost"			
Inside air recirculation			
Boot release from inside car			
Headlight alignment adjustment			
Automatic climate control with pollen filter			
Viscodrive	•		
Radio fitment with rear window aerial and 6 speakers	•	•	•
Radio with RDS, removable panel, autoreverse, CD fitment and 6 speakers	•	•	•
Electronic radio-frequency alarm	•	•	•

= standard
 • = option
 - = not available

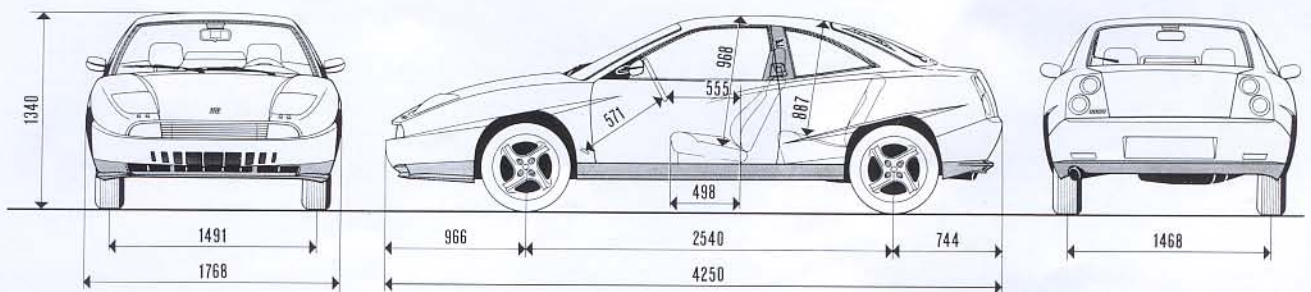

BODY COLOURS

PASTEL



168 Red



258 Yellow



462 Blue

■ Exclusive to 2.0 20v Turbo

METALLIC



180 Dark red



388 Green



466 Light blue



647 Grey



820 Black Ink

INTERIOR UPHOLSTERY

CLOTH



168 Grey/Black

LEATHER



405 Leather



406 Grey



408 Black



414 Sand

INTERIOR TRIM

		Cloth	Leather			
		168 Grey/Black	405 Leather	406 Grey	408 Black	414 Sand
PASTEL						
168	Red	•	○	○	○	○
258	Yellow	•			○	
462	Blue ■	•	○		○	
METALLIC						
180	Dark red	•	○	○	○	○
388	Green	•	○	○	○	○
466	Light blue	•			○	
647	Grey	•	○		○	
820	Black Ink	•	○	○	○	

• = Standard upholstery ○ = Optional upholstery ■ = Exclusive colour for 2.0 20v Turbo version

Trim levels and options may vary in response to specific legal or market requirements.

The information in this brochure is purely indicative.

Fiat reserves the right to make any changes to the models described in this

brochure at any time for technical or market reasons.

Fiat Auto - Pubblicità

Edizione n. 04.2.9219.08 - A - 4/98

Printed in Italy

Officine Grafiche Calderini - Bologna

Printed on chlorine-free paper.

